Maintenance Manual

Booster Regulator

VBA20A

— Contents —

1. Foreword	P.1
2. Maintenance of cylinder and body	P.2
3. Maintenance of governor	P.4
4. Replacement parts list	P.5

1. Foreword

When the booster regulator is disassembled and reassembled for maintenance, read and follow this manual.

Maintenance period depends on air quality and operating conditions, but when either of following situations are seen on the booster regulator, the booster regulator should be considered to come close to its life end and given maintenance at earlier period.

1. The handle is bleeding all the time.

2. Exhaust sound can be heard at an interval of 10 to 20 sec. without air consumption at the secondary side.

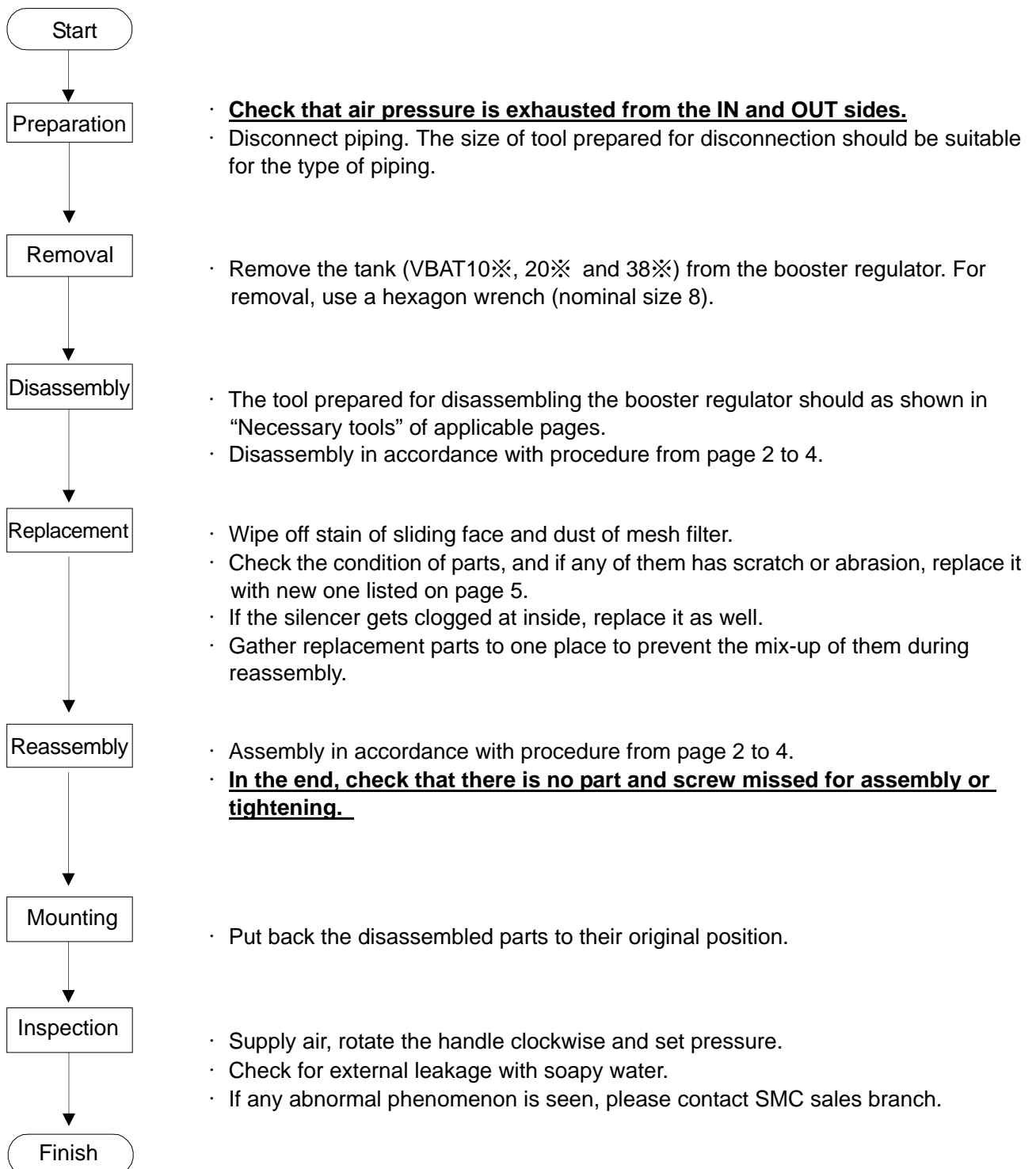

2. Maintenance of cylinder and body

2.1 Maintenance of cylinder

◆Necessary items◆

Socket wrench, Nominal 13 (2pcs) and Nominal 17 (2pcs)
Looseness preventive adhesive (Loctite 542, etc.)

◆Disassembly procedure◆

- 1) **Check air pressure is exhausted from the IN and OUT sides.**
- 2) Loosen the hexagon nuts ⑫ and spring washers ⑪ with the socket wrench, and remove three tie rods ⑩.
- 3) Take off the side covers ⑨ at the right and left.
- 4) Remove the cylinder tubes ⑥ and ⑦ at the right and left sides.
- 5) Loosen the piston nut ⑬ with the socket wrench and remove the piston ④.

◆Maintenance and check◆

- 1) Check any part does not have abrasion, deterioration and deformation. If it has, replace it with new one.
- 2) Wipe off stain from the part whose motion is not smooth, and apply grease.
- 3) If you move onto maintenance of the body, refer to 2.2 Maintenance of body (P.3).

◆Reassembly◆

- 1) Apply grease to the part marked with  in Fig. 1.
- 2) Pass the piston rod ③ through the body ① and assemble the piston ④.
- 3) Apply one drop of Loctite to the thread of the piston nut ⑬ and tighten it with the socket wrench. (Torque 6.3Nm) **The piston is not fixed completely (idles) if it is assembled correctly. Do not tighten it over necessary torque.**
- 4) Mount the O-rings ② to the right and left sides of the body and assembly the cylinder tubes ⑥ and ⑦. **It should be noted the cylinder tube assembled is different for the right and left sides.**
- 5) Mount the O-rings ⑧ to the side covers ⑨ and assemble the side covers to the right and left of the cylinder tubes ⑥ and ⑦.
- 6) Pass through three tie rods ⑩ and tighten them with the hexagon nuts ⑫ and spring washers ⑪. (Torque 12.3Nm)

◆Check◆

- 1) Check the bolts and nuts are tightened to adequate torque.
- 2) Supply air and check pressure setting can be performed.
- 3) Check there is no leakage from connected parts with soapy water.

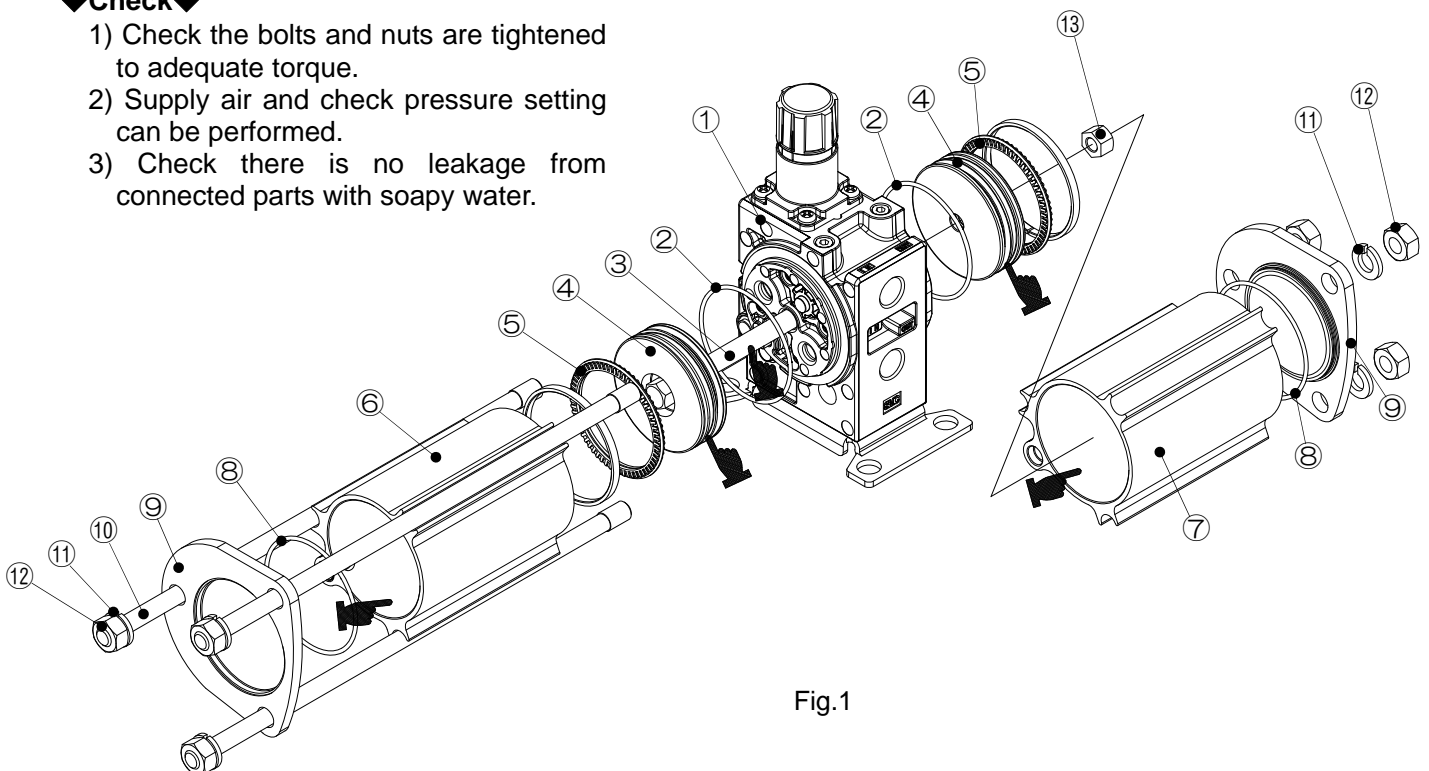

Fig.1

2.2 Maintenance of body

◆Necessary tools◆

- Phillips driver
- Pincettes
- Turbine oil (Turbine oil 32 class 2, Exxon Mobile or like that)

◆Disassembly◆

- 1) Remove four cross recessed round head screws ⑦ at the right and left sides with the Phillips driver.
- 2) Take off the side plates ⑥ at the right and left.
- 3) Take out the check valves ②, ③ and ⑪ through ⑭ from the body ①.
- 4) Take out the switch valves ④ and ⑧ through ⑩ and ⑮ from the body ①.
- 5) Take out the rod seal ⑤ from the body ① with the pincettes.

◆Maintenance and check◆

- 1) Check any part does not have abrasion, deterioration and deformation. If it has, replace it with new one.
- 2) The end of IN port has a mesh filter built in. Remove dust from the filter by air blowing.
- 3) Wipe off stain from the part whose motion is not smooth, and apply grease. Apply one drop of Turbine oil to the switch valve.

◆Reassembly◆

- 1) Mount the switch valves ④ and ⑧ through ⑩ and ⑮. (It is a precise part and should be handled with care.)
- 2) Assembly the check valves ②, ③ and ⑪ through ⑭ to the one side, mount the side plates ⑥ and tighten them with four cross recessed round head screws ⑦. (Tightening torque 1.5Nm) **It should be noted the check valves ② and ③ have different mounting direction.**
- 3) Assembly the check valves to the other side. At this time, hold down the spring to overcome its reaction force.

◆Check◆

- 1) Check there is no gap between the side plates ⑥ and body ①.
- 2) Check the springs are mounted in place and the check valves ② and ③ and switch valve ④ move smoothly.

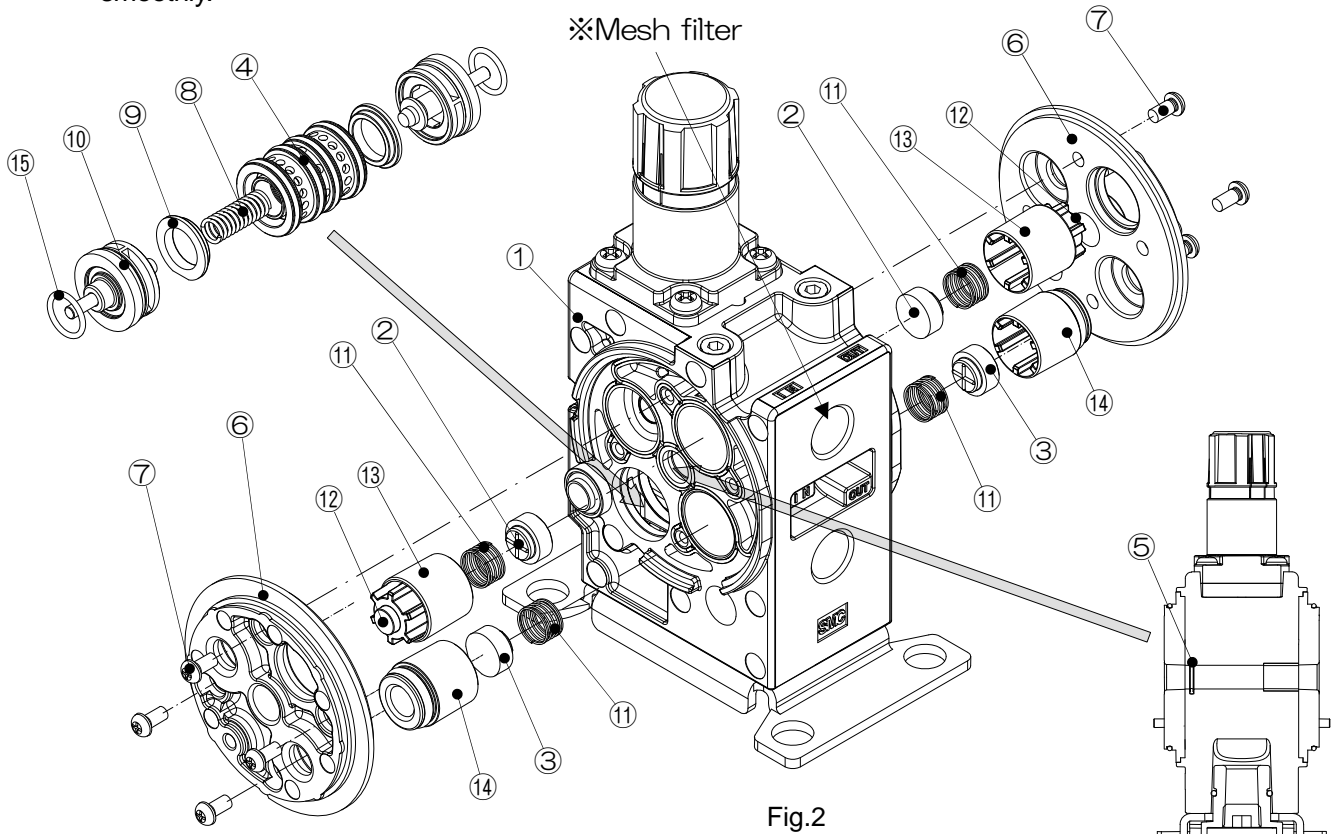

3. Maintenance of governor

◆Necessary tools◆

Phillips driver
Radio pliers

◆Disassembly◆

- 1) **Check air pressure is exhausted from the IN and OUT sides.**
- 2) Rotate the handle counterclockwise back to the end (one direction).
- 3) Remove four cross recessed round head screws ⑦ with the Phillips driver.
- 4) Remove the bonnet assemblies ⑥ and ⑧, pressure adjusting screw ⑤, pressure adjusting spring ④ and diaphragm assembly ③.
- 5) Pull out the governor valve seat assembly ② with the radio pliers.

◆Maintenance and check◆

- 1) Check any part does not have abrasion, deterioration and deformation. If it has, replace it with new one.
- 2) Wipe off stain from the part whose motion is not smooth, and apply grease.

◆Reassembly◆

- 1) Mount the governor valve seat assembly ② with minding the mounting direction of the body ①.
- 2) Mount the diaphragm assembly ③, pressure adjusting spring ④ and pressure adjusting screw ⑤.
- 3) Put on the bonnet assemblies ⑥ and ⑧ and tighten them with four cross recessed round head screws ⑦ using the Phillips driver. (Torque: 3Nm)

◆Check◆

- 1) Check the cross recessed round head screws ⑦ are tightened and supply air.
- 2) The governor starts relieving. Then, rotate the handle to positive direction until relieving stops.
- 3) Check pressure setting to necessary pressure can be performed by handle.
- 4) Check there is no leakage from connected parts with soapy water.

※Maintenance of the governor can be performed without removing the cylinder part.

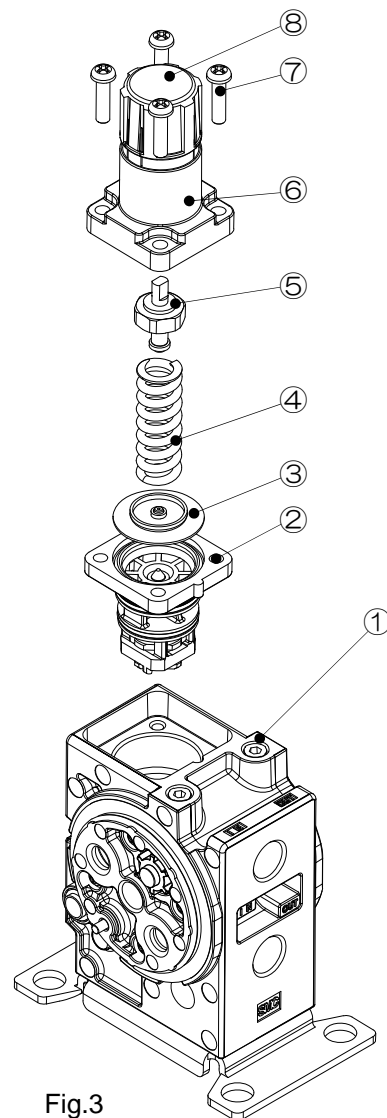

Fig.3

4. Replacement parts list

The replacement part can be ordered with the following part number.

Each set includes the components shown in the right part of table. Refer to the drawing number and item number in this manual to check each part.

Part number	Description	Component			
		Description	Qty.	Dwg. no.	Item no.
KT-VBA20A-1	Booster regulator maintenance parts set	Piston seal	2	Fig. 1	⑤
		Rod seal	1	Fig. 2	⑤
		O-ring (gasket)	2	Fig. 1	②
		Governor assembly	1	Fig. 3	②
		Check valve	4	Fig. 2	②,③
		Cross recessed round head screw (mounting screw)	8	Fig. 2	⑦
		Grease package	1	—	—
KT-VBA20A-2	Switch valve set	Switch valve assembly	1	Fig. 2	④
		Exhaust sleeve	2	Fig. 2	⑨
		Travel spring	1	Fig. 2	⑧
		Push rod guide assembly	2	Fig. 2	⑩
		O-ring	2	Fig. 2	⑮
KT-VBA20A-3	Governor valve seat set	Diaphragm assembly	1	Fig. 3	③
		Governor assembly	1	Fig. 3	②
KT-VBA20A-4	Seal set	Piston seal	2	Fig. 1	⑤
		Rod seal	2	Fig. 2	⑤
		O-ring	4	Fig. 1	②⑧
		Grease package	1	—	—
KT-VBA20A-5	Check valve set	Check valve	4	Fig. 2	②,③
		Check valve spring	4	Fig. 2	⑪
		Plunger	2	Fig. 2	⑫
		Plunger guide	2	Fig. 2	⑬
		Check valve guide assembly	2	Fig. 2	⑭
		Grease package	1	—	—
KT-VBA20A-6	Bonnet set	Bonnet	1	Fig. 3	⑥
		Handle	1	Fig. 3	⑧